

SHADESTONE



ceramica
SANT'AGOSTINO

SHADESTONE



La selezione accurata di punti colore appartenenti alla famiglia dei *warm grey* rende SHADESTONE una collezione dalla personalità estetica forte e, allo stesso tempo, delicata. La "materia pietra" viene caratterizzata da una profonda tridimensionalità e da una varietà grafica pressoché infinita, frutto della tecnologia digitale più avanzata propria di Ceramica Sant'Agostino. Il forte carattere estetico viene attenuato e reso misuratamente elegante dalla palette cromatica raffinata e ricercata del progetto "Shade": un sistema colore sviluppato su cinque tinte contemporanee, declinate secondo un'uniforme gradazione cromatica. La sua anima poliedrica, ideale per i più attuali progetti di design - di interni ed esterni - dell'architettura contemporanea, si esprime, inoltre, attraverso la possibilità di scegliere fra tre differenti superfici: naturale, levigata e strutturata (quest'ultima concepita espressamente per gli esterni e disponibile anche in lastre da 2 cm di spessore).

The careful selection of color points belonging to the family of warm grey makes SHADESTONE a collection with a strong aesthetic personality and, at the same time, delicate. The "stone material" is characterized by a deep three-dimensional graphics and by an almost infinite graphic variety, the result of the most advanced digital technology by Ceramica Sant'Agostino. The strong aesthetic character is softened and made mildly elegant by the sophisticated color palette of the "Shade" project: a color system developed in five contemporary colors, declined accordingly to a uniform color gradation. Its polyhedric soul, ideal for the most current design projects - interior and exterior - of contemporary architecture, is also expressed through the choice of three different surfaces: natural, polished and structured (the latter designed specifically for outdoor use and also available in 2 cm slabs).

UNA SCALA DI CINQUE PUNTI COLORE IN PERFETTA CADENZA FRA LORO

A five points scale in perfectly balanced grading.
Eine Skala mit fünf Farbnuancen, die perfekt miteinander harmonieren
Un nuancier de cinq point de couleur en parfait équilibre entre eux
Шкала из пяти оттенков цветов в прекрасной симфонии между собой

2 | 3



Rettificata

Rectified
Kalibriert
Rectifié
Ректифицированная

Superfici	Nat	Lev	As	As 2.0 (20 mm)
Surfaces Oberflächen Surfaces Поверхность	Superficie naturale Natural surface Natur Oberfläche Surface naturelle Натуральная поверхность	Superficie levigata Polished surface Poliert Oberfläche Surface semi - poli полированная поверхность	Superficie per esterni Surface for external use Berfläche für Aussenbereich Finition pour l'extérieur Поверхность для внешней укладки	Superficie per esterni Surface for external use Berfläche für Aussenbereich Finition pour l'extérieur Поверхность для внешней укладки

DA NUOVI PROGETTI DI ARCHITETTURA ALLA RISTRUTTURAZIONE DI AMBIENTI, IN INTERNO ED ESTERNO

From new architectural projects to
the restructuring of environments,
both indoors and outdoors

Von neuen architektonischen
Projekten bis zur Sanierung von
Innen- und Außenbereichen

Depuis des nouveaux projets
architecturaux jusqu'à la
rénovation en intérieur comme
à l'extérieur

От новых архитектурных
проектов до внутренней
и внешней реставрации
помещений

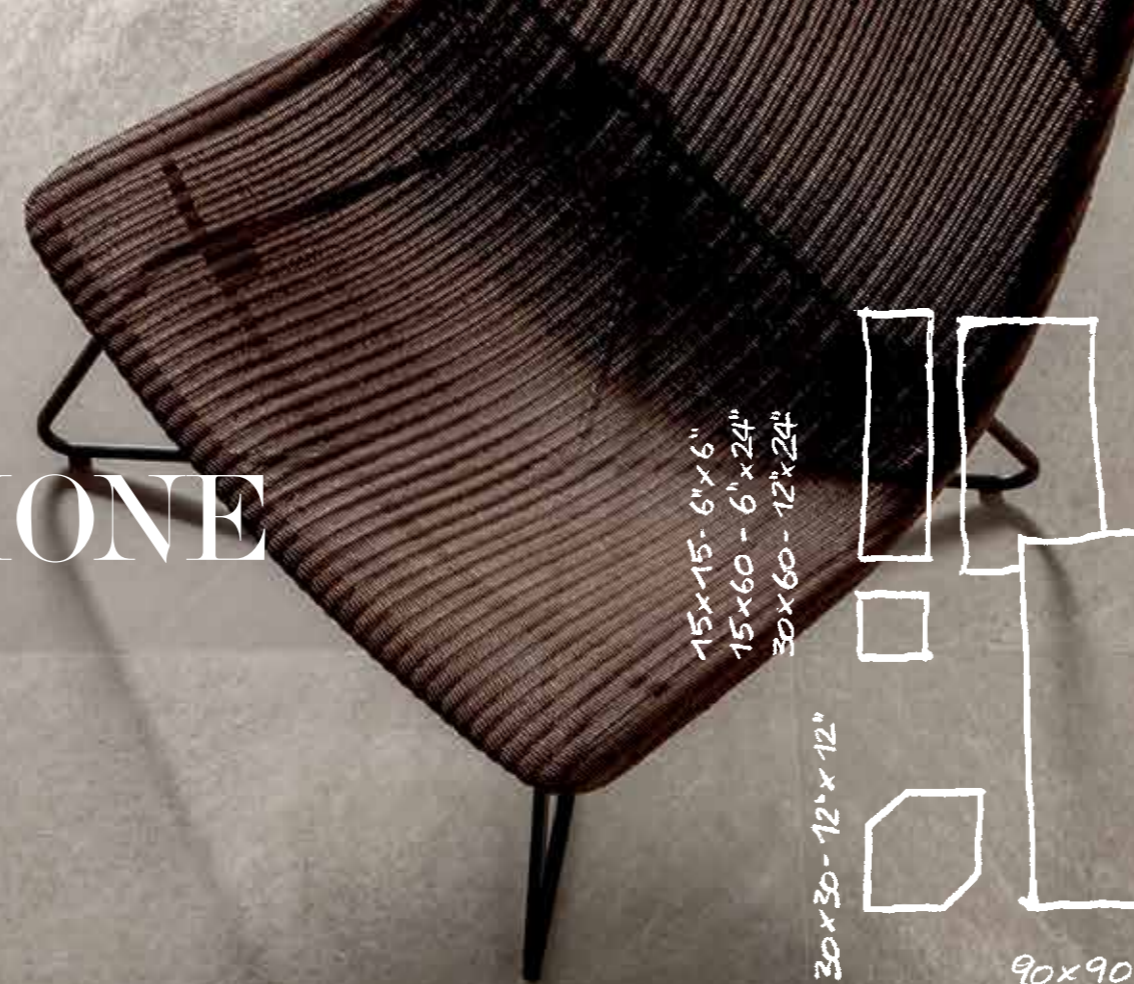

15x15 - 6"x6"
15x60 - 6"x24"
30x60 - 12"x24"

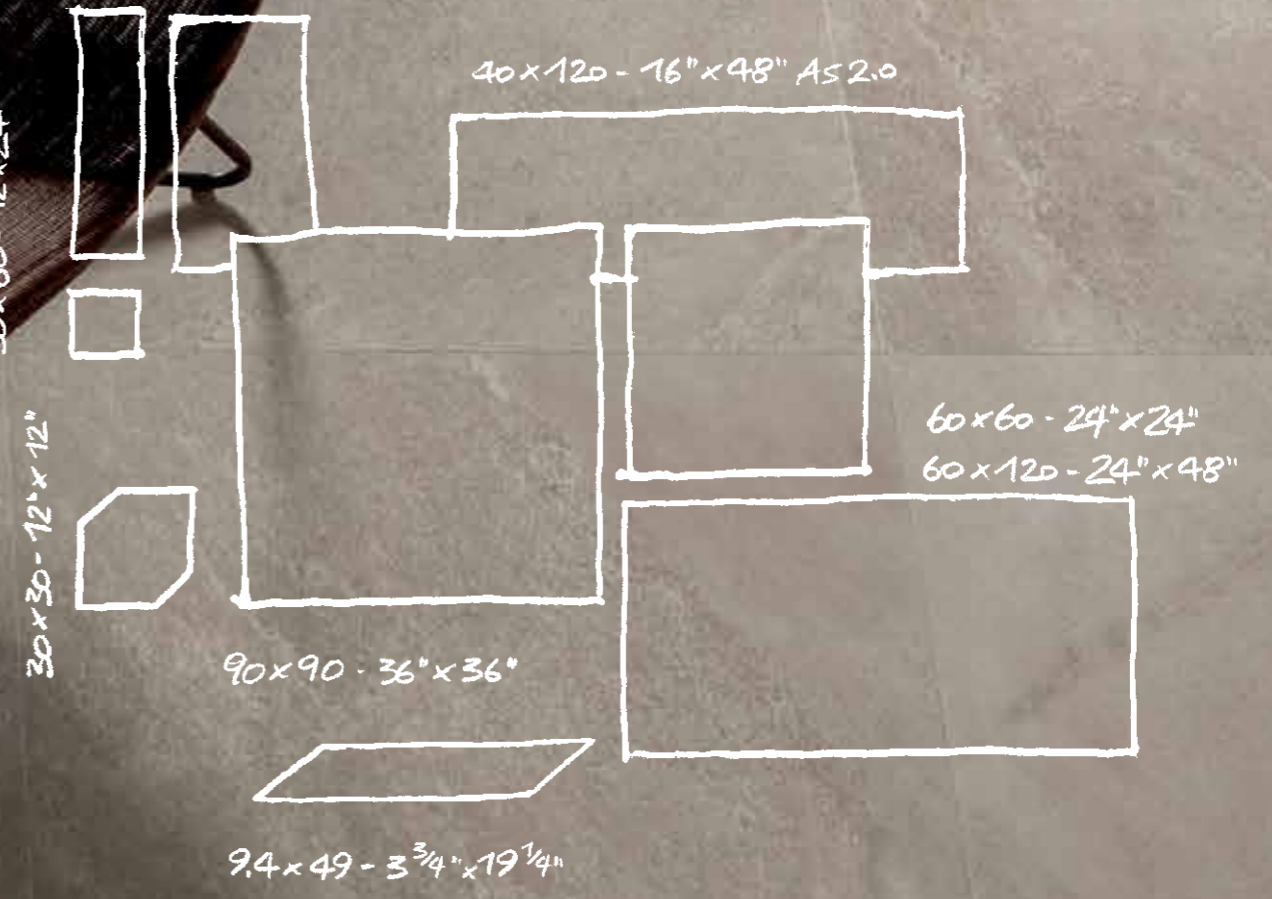

DIGITAL TECHNOLOGY

Questa collezione fa parte del progetto “Supernatural” che raccoglie le nuovissima gamma di prodotti Ceramica Sant’Agostino realizzati con l’innovativo sistema di stampa digitale a getto di inchiostro. Appositamente progettata per l’industria ceramica, questa tecnologia consente infinite possibilità di riproduzione delle immagini garantendo risultati estetici assolutamente naturali. La stampa digitale su ceramica permette di realizzare un numero illimitato di piastrelle diverse dello stesso soggetto, come se fosse materia naturale e non industriale. La definizione della stampa è perfetta anche in caso di superfici con rilievi pronunciati e, cosa fondamentale, arriva fino al bordo estremo della mattonella. Tutto questo ha consentito di riprodurre fedelmente sfumature, ombre, segni e toni di colore che traggono ispirazione dalla natura. La stampa digitale è anche una tecnologia pulita: gli inchiostri vengono utilizzati al 100% senza generare residui di scarto.

This collection is part of the “Supernatural” project that assembles the newest ranges of Ceramica Sant’Agostino products, manufactured with the innovative digital ink-jet printing system. This technology, developed for the ceramic production, offers unlimited opportunities of reproducing images with absolutely natural aesthetic results. The picture shows that the digital printing system on ceramics makes it possible to produce an unlimited number of different tiles of the same subject: like it is real natural material. The printing definition is perfect even in the case of particularly marked reliefs on the surfaces and, above all, decorates the tile from edge to edge. The digital technology permits to reproduce any kind of nuance, shade or tone that draw inspiration from nature. The digital printing system is also a technology respectful of the environment: inks are used at 100% without producing polluting waste.

Diese Serie gehoert zum Plan “Supernatural”, der die neuesten Kollektionen der Ceramica Sant’Agostino sammelt, die mit der erneuernden Technologie Digital hergestellt sind. Ausdruecklich fuer di Keramikindustrie geplant, diese Technologie erlaubt unendliche Moeglichkeiten Bilder wiederzugeben und garantiert absolut natuerliche aestetischen Effekte. Wie Sie in dem Photo feststellen koennen, der Digitaldruck auf Keramik ermoeoglicht die Produktion von unterschiedlichen Fliesen in unbeschraenkte Zahl von dem gleichen Gegenstand: wie echten Naturmaterial. Die Druckschaerfe ist perfekt und bis zum aeussersten Rand der Fliese. Dies hat erlaubt Nuancierungen, Schatten, Zeichen der Natur treulich nachzubilden. Der Digitaldruck ist auch eine saubere Technologie: die Tinten werden un 100% benutzt ohne Abfaelle zu erzeugen.

Cette gamme fait partie du projet “Supernatural” qui rassemble les nouvelles gammes de produits Ceramica Sant’Agostino réalisées avec l’innovant système d’impression numérique à jets d’émaux. Spécialement conçue pour l’industrie céramique, cette technologie permet un nombre non précisé de possibilités de reproduction d’images garantissant des résultats esthétiques absolument naturels. Comme vous pouvez l’observer sur la photo ci-dessus, l’impression numérique consent la réalisation d’un nombre illimité de carreaux tous différents les uns des autres: comme s’il s’agissait de matériel naturel et non industrialisé. La définition de l’impression est parfaite, même dans le cas de surfaces qui présentent des aspérités, et arrive jusqu’à l’extrême bord du carreau. Ceci nous permet de reproduire fidèlement les ombres, détails ou variation de nuances dont l’inspiration est issue de le environnement. L’impression numérique est également une technologie propre : 100% des émaux est utilisé sans laisser trace de résidus polluants.

Данная линия является частью проекта “Supernatural” (сверхъестественный), который включает в себе новейшую гамму продуктов компании Ceramica Sant’Agostino, выполненных с помощью инновационной системы струйной цифровой печати. Специально разработанная для керамической промышленности, данная технология позволяет безграничные возможности воссоздания различных образов, гарантируя, как и в случае с данной линией, результаты, абсолютно естественные с эстетической точки зрения. Цифровая печать на керамике позволяет воплотить в жизнь бесчисленное количество различных плиток на конкретно заданную тему: как будто речь идёт о натуральном материале, а не о промышленном. Четкость печати является идеальной для поверхностей с ярко выраженной рельефностью, и что самое главное, доходит до самых краёв плитки. Всё вышеописанное позволяет достоверно воспроизводить оттенки, тени, отпечатки и тона цвета, которые черпают своё вдохновение из самой природы”. Цифровая печать также является чистой технологией: чернила используются на 100% без создания отработанных материалов.

digital technology

Formato Size Formate Format Форматы	Numero grafiche Number of patterns Grafische Nummer Nombre d’images Количество графических оформлений
90x90 - 36”x36”	40
60x120 - 24”x48”	30
60x60 - 24”x24”	55
60x60 - 24”x24” Mix	6
30x60 - 12”x24”	110
15x60 - 6”x24”	140
15x15 - 6”x6”	200
40x120 - 16”x48” As 2.0	30

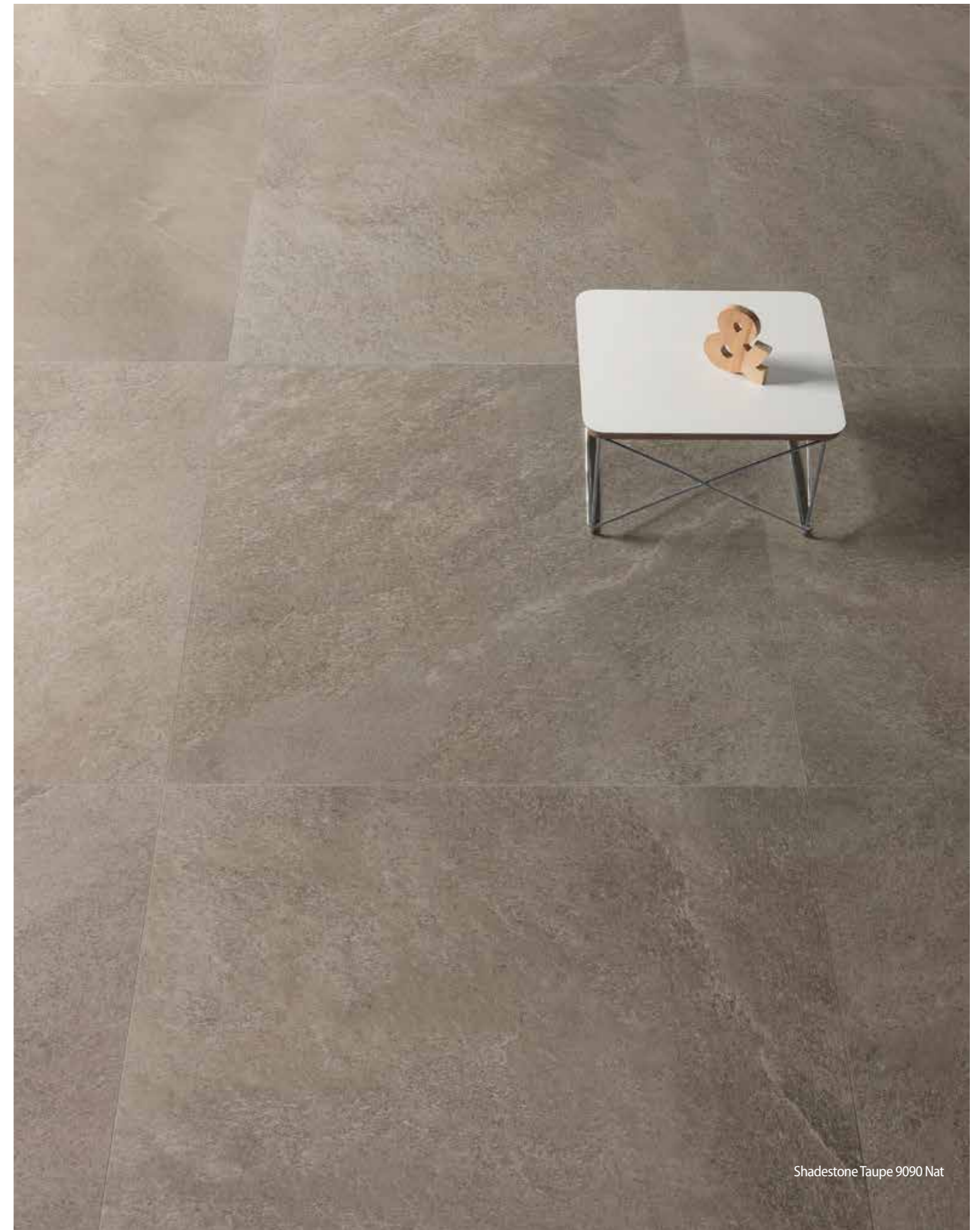

Shadestone Taupe 9090 Nat

SUPERFICIE NON STRUTTURATA CON UNA PROFONDA TRIDIMENSIONALITÀ VISIVA

8 | 9

Unstructured surface with a deep three-dimensional visual effect

Eine nicht strukturierte Oberfläche mit einer tiefen visuellen Dreidimensionalität

Surface sans structure avec un effet visuel tridimensionnelle

Неструктурная поверхность с глубиной трёхdimensionального изображения

L'unicità di questo materiale è data dal movimento del disegno, dai particolari foto-grafici che caratterizzano ogni centimetro di ogni singola lastra e dai giochi di luce ottenuti con l'applicazione diretta in fase di stampa di inchiostri lucidi, scelti e calibrati appositamente per enfatizzarne la resa realistica. Questo uso alternato di smalti lucido e opaco che si alternano incastrati nella grafica - effettiva novità tecnologica e espressione attualmente più evoluta del processo digitale - fa sì che, visivamente, sia come osservare un vero spaccato di pietra. Ma se provate a passarci sopra la mano, vi renderete conto che la superficie è perfettamente liscia, quindi facilmente pulibile e pratica da gestire, dalla posa alla manutenzione quotidiana. Queste sono le qualità che fanno di SHADESTONE un prodotto superiore.

The uniqueness of this material is given by the movement of the drawing, by the particular photographs which characterize every centimeter of each slab and by the play of light with the direct application in printing of inks transparencies, chosen and calibrated specifically to emphasize the realistic performance. This alternate use of shiny and opaque glazes - an actual new technology and expression of the currently most advanced digital process - means that, visually, it looks like a real piece of stone. By touch, you'll realize that the surface is perfectly smooth, therefore easy to clean and easy to manage, from the installation to daily maintenance. These are the qualities making SHADESTONE a superior product.

Die Besonderheit dieses Materials liegt in der Lebendigkeit des Designs, in den fotografischen Details, die jeden Zentimeter jeder einzelnen Platte kennzeichnen, und den Lichtspielen, die durch die direkte Aufbringung von leuchtender, eigens zur Verstärkung des realistischen Eindrucks gewählter und angepasster Farben während des Drucks erzielt werden. Die kombinierte Verwendung von glänzenden und matten Lacken, die sich in der Grafik abwechseln und ineinander übergreifen - was die eigentliche technologische Neuheit und den derzeit am weitesten entwickelten Ausdruck des digitalen Verfahrens darstellt - sorgt dafür, dass Sie den Eindruck bekommen, einen gespaltenen Naturstein zu betrachten. Aber wenn Sie Ihre Hand darüber gleiten lassen, dann werden Sie feststellen, dass die Oberfläche völlig glatt und somit einfach zu reinigen und von der Verlegung bis zur täglichen Wartung praktisch zu handhaben ist. Das sind die Qualitäten, die SHADESTONE zu einem hochwertigen Produkt machen.

L'unicité de ce matériel est provoquée par le mouvement du décor, par la précision au niveau des photos de chaque centimètre de chaque dalle et par les jeux de lumière obtenus avec la directe application, pendant l'impression, d'émaux brillants choisis pour en mettre en valeur leur effet naturel. Cette utilisation alternée d'émaux mat et brillants dans le décor, sont une nouveauté technologique du numérique, ça permet d'avoir un effet tranche de pierre. Si vous essayez d'y faire passer la main dessus, vous rendrez compte que la surface est parfaitement lisse, donc facile à l'entretien, de la pose au nettoyage. Celles-ci sont les caractéristiques qui rendent SHADESTONE un produit supérieur.

Неповторимость данного материала обеспечивается движением рисунка, фотографическими деталями, которые характеризуют каждый сантиметр каждой отдельной плитки, и игрой света, благодаря прямому нанесению на этапе печати блестящих цветов, которые выбраны и откалиброваны специально с целью подчеркнуть реалистичный результат. Это попеременное использование блестящей и матовой эмали, которые чередуются в графическом изображении - действительное технологическое новшество и передовое достижение цифрового процесса - позволяет поверить, что перед вами разрез натурального камня. Но если вы проведёте рукой, вы поймёте, что поверхность безупречно гладкая, а значит, не вызывает затруднений при очистке и отличается практичностью как в укладке, так и в ежедневном уходе. Благодаря этим свойствам SHADESTONE - это изделие высочайшего качества.

Shadestone Grey 9090 Nat





Shadestone Grey 9090 Nat



< Shadestone Dark 9090 Nat

Floor / Shadestone Light 9090 Nat

Shadestone Mix Grey 6060 Nat

SINTESI DI ESTETICA, AMPIA GAMMA, LIBERTA DI UTILIZZO E PERFORMANCE TECNICHE ELEVATE

14 | 15

Synthesis of aesthetics, wide range,
several uses, and high technical
performance

Ausdrucksstarke Ästhetik, vielseitige
Verwendungsmöglichkeiten und
hohe technische Leistungen

Synthèse d'esthétique, vaste gamme,
liberté d'utilisation, et performances
techniques très élevés

Эстетическая простота, широкая
гамма, свобода применения и
высокие технические качества

Chevron Stone Dark Nat





Chevron Stone Sand Nat





< Shadestone Taupe 1560 Nat
 Shadestone Mix Taupe 6060 Nat
 Floor / Code Stone Light Nat



Shadestone Taupe 1515 Nat
 Floor / Shadestone Taupe 1515 Nat



Shadestone Light 1560 Nat
Shadestone Grey 1560 Nat
Shadestone Mix Light 6060 Nat
Floor / Code Stone Grey Nat



> Code Stone Grey Nat
Floor / Code Stone Grey Nat

EFFETTO PIETRA EVOLUTO E RICERCATO PER UN DESIGN D'INTERNI URBANO

22 | 23

Advanced and refined stone effect
for an urban interior design

Ein moderner und raffinierter
Steineffekt für eine
Innenarchitektur mit urbanem
Touch

Effet pierre recherché pour un
design d'intérieur urbaine

Эффект камня, утонченный и
возвышенный стиль для дизайна
помещений в городском стиле

Shadestone Dark 60120 Lev





Shadestone Dark 60120 Lev



Shadestone Sand 9090 Lev





“MATERICITÀ MINIMALE” ESSENZA DI FORZA RAFFINATA

“Minimal materiality: refined
essence of strength

“Minimale Gegenständlichkeit”:
eine elegante Konzentration von
Kraft

“Matière minimaliste”: expression
de force raffinée

“Минимальная материальность”:
квинтэссенция изысканной силы



< Shadestone Grey 60120 Nat

outdoor / Shadestone Grey 6060 As
Pictart Grey 15120 (PICTART Collection)

Shadestone Grey 60120 Nat



Shadestone Grey 40120 As 2.0

AS 2.0

Antiscivolo	Antislip	Trittsicher	Antidérapant	Противоскользящий
Spessore 20 mm	Thickness 20 mm	Stärke 20 mm	Epaisseur 20 mm	Толщина 20 MM
Resistente agli sbalzi termici	Resistant to thermal shock	Unempfindlich gegen temperaturschwankungen	Résistant aux chocs thermiques	Устойчивый к перепадам температур
Ingelivo - Ignifugo	Frost resistant - Fire resistant	Frostsicher - Feuerfest	Ingélif - Résistant au feu	Морозостойкий
Inalterabile nel tempo	Time resistant	Zeitbeständig (lange lebensdauer)	Inaltérable dans le temps	Огнеупорный
Facilissimo da posare	Easy to lay	Leichte verlegung	Mise en œuvre très simple	Долговечный
Nel caso di posa a secco è semplice da riposizionare o rimuovere, non servono lavori di muratura	In case of dry tiling it's easy to replace or remove, no walling	Bei der trockenen verlegung einfach zu positionieren oder zu entfernen, es sind keine mauerarbeiten erforderlich	Dans le cas de pose à sec est facile à replacer ou enlever, ils ne sont pas nécessaires des travaux de maçonnerie	Простой в укладке: при укладке сухим методом его легко установить и снять, без кладочного раствора.
Pavimentazioni sopraelevate *	Raised floors *	Doppelböden *	Pose sur plots *	Мощение на приподнятом основании *



Rettificata
Rectified
Kalibriert
Rectifié
Ректифицированная

40x120 - 16"x48"



Posa a secco su erba
Dry laying on grass
Trockene Verlegung auf Gras
Pose sur pelouse
Сухая укладка на травяной газон



Posa a secco su ghiaia
Dry laying on gravel
Trockene Verlegung auf Kies
Pose sur gravillon
Сухая укладка на щебень



Posa a secco su sabbia
Dry laying on sand
Trockene Verlegung auf Sand
Pose sur sable
Сухая укладка на песок

*** AVVERTENZE PER LA POSA SOPRAELEVATA**
Il formato 40x120 in 20 mm di spessore è ritenuto idoneo per la posa su massetto, su ghiaia, su sabbia, su erba, o su supporti ad una altezza massima di 2 cm utilizzando 6 supporti per lastra in modo da distribuire uniformemente i carichi. Per una sopraelevazione compresa tra i 2 ed i 10 cm è necessaria l'applicazione di una rete in fibra di vetro nella parte inferiore della lastra (foglio di acciaio zincato o rete plus per il formato 430x120). Una sopraelevazione superiore ai 10 cm è vincolata alla applicazione alla parte retrostante della lastra di un foglio di lamiera zincata.

*** WARNINGS FOR RAISED FLOOR LAYING**
Size 40x120 with 20 mm thickness is considered suitable for laying on screed, gravel, sand, grass or supports at a maximum height of 2 cm, using 6 supports per slab in order to distribute loads uniformly. For raised laying between 2 and 10 cm you must apply a fibre glass mesh to the rear of the slab (galvanised steel sheet or plus mesh for size 40x120). For raised floors of more than 10 cm, galvanised steel sheet must be applied to the rear of the slab.

*** HINWEISE FÜR DIE INSTALLATION ALS DOPPELBODEN**
Das Format 40x120 in 20 mm Stärke eist sich für die Verlegung auf Estrich, Kies, Sand, Gras oder Trägern mit einer maximalen Höhe von 2 cm, indem man 6 Stützen pro Platte verwendet, um die Lasten gleichmäßig zu verteilen. Für eine Verlegung in einer Höhe zwischen 2 und 10 cm muss ein Glasfasernetz auf der Unterseite der Platte angebracht werden (verzinkte Stahlfolie oder Plus-Netz beim Format 40x120). In einer Höhe über 10 cm darf nur verlegt werden, wenn man eine verzinkte Blechfolie auf der Rückseite der Platte anbringt.

*** MISES EN GARDE POUR LA POSE SURÉLEVÉE**
Le format 40x120 en 20 mm d'épaisseur est appropriés à la pose sur chape, gravier, sable, pelouse ou sur vérins à une hauteur maximum de 2 cm, en utilisant 6 vérins par plaque, de manière à répartir équitablement les charges. Pour une surélévation comprise entre 2 et 10 cm, il est nécessaire d'appliquer un filet en fibre de verre au dos de la plaque (feuille d'acier galvanisé ou filet « plus » pour le format de 40x120). Une surélévation de plus de 10 cm exige l'application d'une feuille de tôle galvanisée au dos de la plaque.

*** РЕКОМЕНДАЦИИ ПО УКЛАДКЕ ПЛИТ НА ФАЛЬШПОЛ**
Форматы плит 40x120 толщиной 20 мм считаются пригодными для укладки на стяжку, гравий, песок, траву или на основания высотой не более 2 см при использовании 6 стоек для каждой плиты для равномерного распределения нагрузок. Для поднятия уровня пола на высоту от 2 до 10 см необходимо приклеивать к нижней стороне плит сетку из стекловолокна (лист оцинкованной стали или сетку plus для формата 40x120). При поднятии уровня пола на высоту более 10 см обязательно следует крепить к нижней стороне плит лист из оцинкованной стали.

TECHNICAL INFORMATION

Gres porcellanato

Rettificata

Porcelain

Rectified

Feinsteinzeug

Kalibriert

Grès cérame

Rectifié

Керамогранит

Ректифицированная



RET V2

Lev	4			10mm	EN 14411 APPENDICE G Bla GL
Nat	5	R10	A+B	10mm	EN 14411 APPENDICE G Bla GL
As	5	R11	A+B+C	10mm	EN 14411 APPENDICE G Bla GL
As 2.0	5	R11	A+B+C	20mm	EN 14411 APPENDICE G Bla UGL



Escluso As 2.0
As 2.0 excluded
As 2.0 ausgeschlossen
As 2.0 exclu
Исключая As 2.0



Light

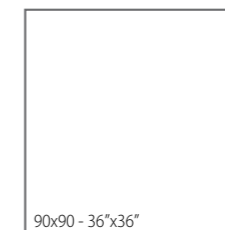

90x90 - 36"x36"

Shadestone Light 9090 Nat

Shadestone Light 9090 Lev

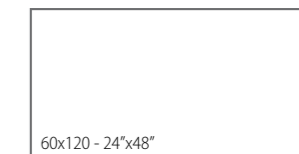

60x120 - 24"x48"

Shadestone Light 60120 Nat

Shadestone Light 60120 Lev

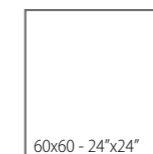

60x60 - 24"x24"

Shadestone Light 6060 Nat

Shadestone Light 6060 Lev

Shadestone Light 6060 As

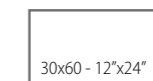

30x60 - 12"x24"

Shadestone Light 3060 Nat

Shadestone Light 3060 Lev

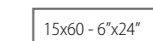

15x60 - 6"x24"

Shadestone Light 1560 Nat

Shadestone Light 1560 Lev



40x120 - 16"x48"

Shadestone Light 40120 As 2.0



15x15 - 6"x6"

Shadestone Light 1515 Nat



Sand

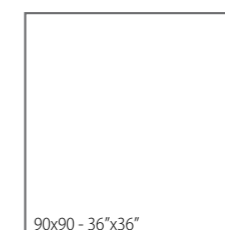

90x90 - 36"x36"

Shadestone Sand 9090 Nat

Shadestone Sand 9090 Lev



60x120 - 24"x48"

Shadestone Sand 60120 Nat

Shadestone Sand 60120 Lev

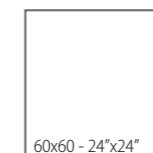

60x60 - 24"x24"

Shadestone Sand 6060 Nat

Shadestone Sand 6060 Lev

Shadestone Sand 6060 As

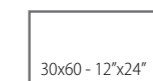

30x60 - 12"x24"

Shadestone Sand 3060 Nat

Shadestone Sand 3060 Lev

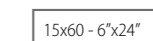

15x60 - 6"x24"

Shadestone Sand 1560 Nat

Shadestone Sand 1560 Lev



40x120 - 16"x48"

Shadestone Sand 40120 As 2.0



15x15 - 6"x6"

Shadestone Sand 1515 Nat

Lev	4			10mm	EN 14411 APPENDICE G Bla GL
Nat	5	R10	A+B	10mm	EN 14411 APPENDICE G Bla GL
As	5	R11	A+B+0	10mm	EN 14411 APPENDICE G Bla GL
As 2.0	5	R11	A+B+0	20mm	EN 14411 APPENDICE G Bla UGL



Taupe



Shadestone Taupe 9090 Nat

Shadestone Taupe 9090 Lev



Shadestone Taupe 60120 Nat

Shadestone Taupe 60120 Lev

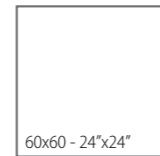

Shadestone Taupe 6060 Nat

Shadestone Taupe 6060 Lev

Shadestone Taupe 6060 As

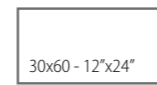

Shadestone Taupe 3060 Nat

Shadestone Taupe 3060 Lev

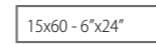

Shadestone Taupe 1560 Nat

Shadestone Taupe 1560 Lev



Shadestone Taupe 40120 As 2.0



Shadestone Taupe 1515 Nat



Grey



Shadestone Grey 9090 Nat

Shadestone Grey 9090 Lev

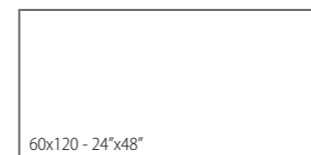

Shadestone Grey 60120 Nat

Shadestone Grey 60120 Lev

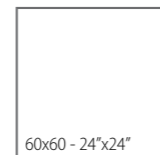

Shadestone Grey 6060 Nat

Shadestone Grey 6060 Lev

Shadestone Grey 6060 As

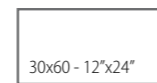

Shadestone Grey 3060 Nat

Shadestone Grey 3060 Lev

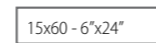

Shadestone Grey 1560 Nat

Shadestone Grey 1560 Lev

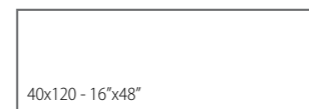

Shadestone Grey 40120 As 2.0



Shadestone Grey 1515 Nat



Dark

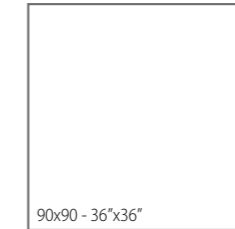

Shadestone Dark 9090 Nat

Shadestone Dark 9090 Lev



Shadestone Dark 60120 Nat

Shadestone Dark 60120 Lev

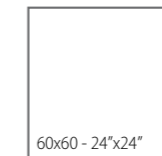

Shadestone Dark 6060 Nat

Shadestone Dark 6060 Lev

Shadestone Dark 6060 As

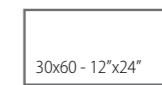

Shadestone Dark 3060 Nat

Shadestone Dark 3060 Lev

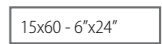

Shadestone Dark 1560 Nat

Shadestone Dark 1560 Lev



Shadestone Dark 40120 As 2.0

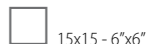

Shadestone Dark 1515 Nat

SHADESTONE



Lev	4	10mm	EN 14411 APPENDICE G Bla GL
Nat	5 R10 A+B	10mm	EN 14411 APPENDICE G Bla GL
As	5 R11 A+B+0	10mm	EN 14411 APPENDICE G Bla GL
As 2.0	5 R11 A+B+0	20mm	EN 14411 APPENDICE G Bla UGL



60x60 - 24"x24"
Shadestone Mix Light 6060 Nat



60x60 - 24"x24"
Shadestone Mix Taupe 6060 Nat



60x60 - 24"x24"
Shadestone Mix Grey 6060 Nat

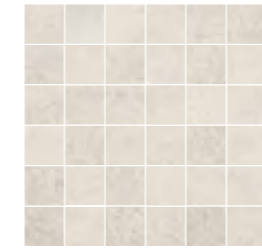

30x30 - 12"x12"
Mosaico Shadestone Light Nat
Mosaico Shadestone Light Lev



30x30 - 12"x12"
Mosaico Shadestone Sand Nat
Mosaico Shadestone Sand Lev

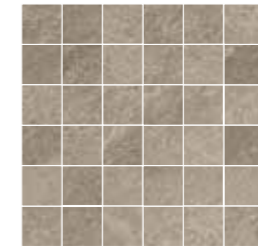

30x30 - 12"x12"
Mosaico Shadestone Taupe Nat
Mosaico Shadestone Taupe Lev

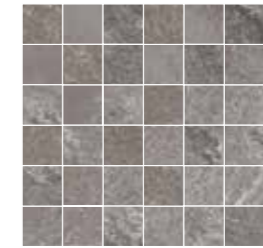

30x30 - 12"x12"
Mosaico Shadestone Grey Nat
Mosaico Shadestone Grey Lev

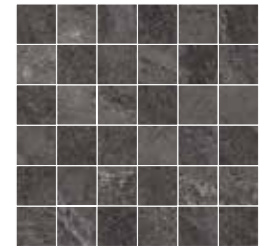

30x30 - 12"x12"
Mosaico Shadestone Dark Nat
Mosaico Shadestone Dark Lev



9,4x49 - 3¾"x19¼"
Chevron Stone Light Nat



9,4x49 - 3¾"x19¼"
Chevron Stone Sand Nat



9,4x49 - 3¾"x19¼"
Chevron Stone Taupe Nat



9,4x49 - 3¾"x19¼"
Chevron Stone Grey Nat

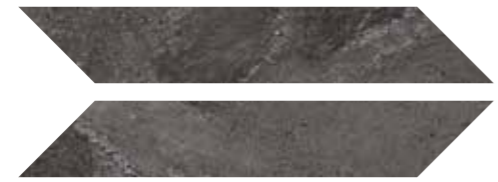

9,4x49 - 3¾"x19¼"
Chevron Stone Dark Nat

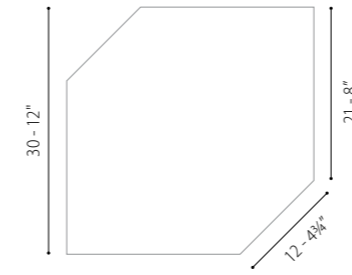
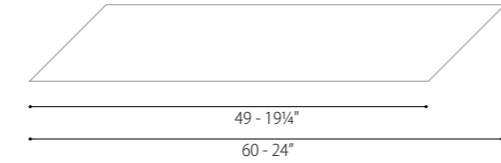

30x30 - 12"x12"
Code Stone Light Nat



30x30 - 12"x12"
Code Stone Sand Nat

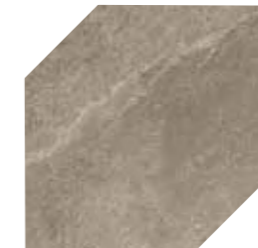

30x30 - 12"x12"
Code Stone Taupe Nat



30x30 - 12"x12"
Code Stone Grey Nat

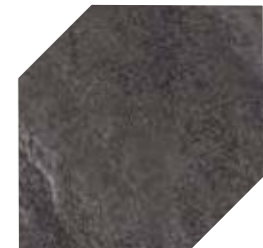

30x30 - 12"x12"
Code Stone Dark Nat

Informazioni Tecniche





Technical Data

Technische Daten

Information Techniques

Техническая Информация

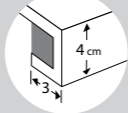
Pezzi speciali - Special pieces - Spezial-Stücke - Pièces spéciales - Специальных элементов

				
33x120 - 13"x48" Gradone 120 Shadestone	33x120 - 13"x48" Gradone Ang. 120 Sx Shadestone	33x120 - 13"x48" Gradone Ang. 120 Dx Shadestone	9,5 x 60 - 3 7/8" x 24" Battiscopa Shadestone	1,5x30 - 3/4" x 12" Quarter Round Shadestone
Light Sand Taupe Grey Dark	Light Sand Taupe Grey Dark	Light Sand Taupe Grey Dark	Light Sand Taupe Grey Dark Nat	Light Sand Taupe Grey Dark

Imballi e pesi - Packing and weights - Verpackungen und Gewichte - Emballage et poids - Вес и упаковка

Formato Size Format форматы (cm)	Scatola/Box				Pallet			Montato su rete On net Auf Netz Sur trame Собрана на сетке
	Pzz./Scat. Pcs/Box	Mq/Scat. Sqm/Box	Kg/Scat. Kg/Box	Kg/Mq Kg/Sqm	Scatole Boxes	Mq Sqm	Kg kg в палете	
60x120	2	1,44	31,7	22	20	28,8	634	<
90x90	1	0,81	17,8	22	36	29,16	641	
60x60	4	1,44	31,7	22	30	43,2	951	
60x60 Mix	4	1,44	31,7	22	30	43,2	951	
60x60 As	4	1,44	31,7	22	30	43,2	951	
30x60	7	1,26	27,7	22	32	40,32	886	
15x60	14	1,26	27,7	22	32	40,32	886	
40x120 As 20	2	0,96	43,2	45	24	23,04	1.037	
15x15	36	0,81	17,8	22	75	60,75	1.335	
30x30 Mosaico	6	0,54	11,3	20,9	60	32,4	678	
30x30 Code Esagono	13	1,07	23,5	22	40	42,8	940	
9,4x49 Chevron	4dx- 4sx	0,37	8,1	21,9	96	35,52	778	

Consigli per la posa - Suggestion for laying - Ratschläge für die Verlegung - Conseil pour la pose - Советы по укладке

<p>Viste le caratteristiche della serie si consiglia:</p> <ul style="list-style-type: none"> Fuga 2mm Per i formati 30x60 e 15x60 si consigliano pose affiancate o a correre sfalsate di 3/4 Per i formati 60x120 e 40x120 si consigliano pose affiancate o a correre sfalsate di 4/5 Colore fuga <table border="0" style="margin-left: 20px;"> <tr><td>Dark</td><td>Mapei 114 - Kerakoll 05</td></tr> <tr><td>Grey</td><td>Mapei 113 - Kerakoll 04</td></tr> <tr><td>Light</td><td>Mapei 103 - Kerakoll 51</td></tr> <tr><td>Sand</td><td>Mapei 133 - Kerakoll 03</td></tr> <tr><td>Taupe</td><td>Mapei 134 - Kerakoll 04</td></tr> </table> 	Dark	Mapei 114 - Kerakoll 05	Grey	Mapei 113 - Kerakoll 04	Light	Mapei 103 - Kerakoll 51	Sand	Mapei 133 - Kerakoll 03	Taupe	Mapei 134 - Kerakoll 04	<p>Considering the characteristics of this serie we suggest:</p> <ul style="list-style-type: none"> 2 mm joint For the sizes 30x60 and 15x60 lined up laying or 3/4 staggered laying is suggested For the sizes 60x120 and 40x120 lined up laying or 4/5 staggered laying is suggested Grouting colour <table border="0" style="margin-left: 20px;"> <tr><td>Dark</td><td>Mapei 114 - Kerakoll 05</td></tr> <tr><td>Grey</td><td>Mapei 113 - Kerakoll 04</td></tr> <tr><td>Light</td><td>Mapei 103 - Kerakoll 51</td></tr> <tr><td>Sand</td><td>Mapei 133 - Kerakoll 03</td></tr> <tr><td>Taupe</td><td>Mapei 134 - Kerakoll 04</td></tr> </table> 	Dark	Mapei 114 - Kerakoll 05	Grey	Mapei 113 - Kerakoll 04	Light	Mapei 103 - Kerakoll 51	Sand	Mapei 133 - Kerakoll 03	Taupe	Mapei 134 - Kerakoll 04	<p>Im Hinblick auf die Eigenschaften der Serie es empfiehlt sich:</p> <ul style="list-style-type: none"> 2 mm. Fuge Für Formate 30x60 und 15x60 neben verlegt oder 3/4 versetzt Für Formate 60x120 und 40x120 neben verlegt oder 4/5 versetzt Farbe der Fuge <table border="0" style="margin-left: 20px;"> <tr><td>Dark</td><td>Mapei 114 - Kerakoll 05</td></tr> <tr><td>Grey</td><td>Mapei 113 - Kerakoll 04</td></tr> <tr><td>Light</td><td>Mapei 103 - Kerakoll 51</td></tr> <tr><td>Sand</td><td>Mapei 133 - Kerakoll 03</td></tr> <tr><td>Taupe</td><td>Mapei 134 - Kerakoll 04</td></tr> </table> 	Dark	Mapei 114 - Kerakoll 05	Grey	Mapei 113 - Kerakoll 04	Light	Mapei 103 - Kerakoll 51	Sand	Mapei 133 - Kerakoll 03	Taupe	Mapei 134 - Kerakoll 04	<p>Vu les caractéristiques de la série, nous conseillons:</p> <ul style="list-style-type: none"> Joint 2 mm Pour les formats 30x60 et 15x60, il est conseillé une pose alignée ou une pose décalée au 3/4 Pour les formats 60x120 et 40x120, il est conseillé une pose alignée ou une pose décalée au 4/5 Couleur de joint <table border="0" style="margin-left: 20px;"> <tr><td>Dark</td><td>Mapei 114 - Kerakoll 05</td></tr> <tr><td>Grey</td><td>Mapei 113 - Kerakoll 04</td></tr> <tr><td>Light</td><td>Mapei 103 - Kerakoll 51</td></tr> <tr><td>Sand</td><td>Mapei 133 - Kerakoll 03</td></tr> <tr><td>Taupe</td><td>Mapei 134 - Kerakoll 04</td></tr> </table> 	Dark	Mapei 114 - Kerakoll 05	Grey	Mapei 113 - Kerakoll 04	Light	Mapei 103 - Kerakoll 51	Sand	Mapei 133 - Kerakoll 03	Taupe	Mapei 134 - Kerakoll 04	<p>В силу характеристик данной серии рекомендуется:</p> <ul style="list-style-type: none"> Шов 2 мм Для форматов 30x60 и 15x60 рекомендуется укладка рядами или со смещением на 3/4 Для форматов 60x120 и 40x120 рекомендуется укладка рядами или со смещением на 4/5 цвет шов <table border="0" style="margin-left: 20px;"> <tr><td>Dark</td><td>Mapei 114 - Kerakoll 05</td></tr> <tr><td>Grey</td><td>Mapei 113 - Kerakoll 04</td></tr> <tr><td>Light</td><td>Mapei 103 - Kerakoll 51</td></tr> <tr><td>Sand</td><td>Mapei 133 - Kerakoll 03</td></tr> <tr><td>Taupe</td><td>Mapei 134 - Kerakoll 04</td></tr> </table> 	Dark	Mapei 114 - Kerakoll 05	Grey	Mapei 113 - Kerakoll 04	Light	Mapei 103 - Kerakoll 51	Sand	Mapei 133 - Kerakoll 03	Taupe	Mapei 134 - Kerakoll 04
Dark	Mapei 114 - Kerakoll 05																																																					
Grey	Mapei 113 - Kerakoll 04																																																					
Light	Mapei 103 - Kerakoll 51																																																					
Sand	Mapei 133 - Kerakoll 03																																																					
Taupe	Mapei 134 - Kerakoll 04																																																					
Dark	Mapei 114 - Kerakoll 05																																																					
Grey	Mapei 113 - Kerakoll 04																																																					
Light	Mapei 103 - Kerakoll 51																																																					
Sand	Mapei 133 - Kerakoll 03																																																					
Taupe	Mapei 134 - Kerakoll 04																																																					
Dark	Mapei 114 - Kerakoll 05																																																					
Grey	Mapei 113 - Kerakoll 04																																																					
Light	Mapei 103 - Kerakoll 51																																																					
Sand	Mapei 133 - Kerakoll 03																																																					
Taupe	Mapei 134 - Kerakoll 04																																																					
Dark	Mapei 114 - Kerakoll 05																																																					
Grey	Mapei 113 - Kerakoll 04																																																					
Light	Mapei 103 - Kerakoll 51																																																					
Sand	Mapei 133 - Kerakoll 03																																																					
Taupe	Mapei 134 - Kerakoll 04																																																					
Dark	Mapei 114 - Kerakoll 05																																																					
Grey	Mapei 113 - Kerakoll 04																																																					
Light	Mapei 103 - Kerakoll 51																																																					
Sand	Mapei 133 - Kerakoll 03																																																					
Taupe	Mapei 134 - Kerakoll 04																																																					

Certificazioni - Certifications - Zertifizierungen - Certifications - Сертификаты

<p>Coefficient of friction ASTM C 1028 - 2006</p> <p>Dry μ > 0,6 Wet μ > 0,6 Natural Surface - Anti Slip</p>	<p>BOT 3000 (DCOF) ANSI A 137.1:2012 VERSION 1</p> <p>WET DCOF ≥ 0,42 Natural Surface - Anti Slip</p>	  
<p>* ANAB Serie in fase di certificazione - Collection under certification - Die Zertifikaten werden gerade hergestellt - Série en phase de rectification - Серия на стадии сертификации</p>		

Simbologia - Symbols - Symbole - Symboles - Условные Обозначения

<p>5 4</p> <p>Gruppo di usura superficiale</p> <p>Surface abrasion group</p> <p>Abrieb</p> <p>Degré de usure superficielle</p> <p>Группа Истираемости Поверхности</p>	<p>R10 R11</p> <p>DIN 51130</p> <p>Classificazione antiscivolosità</p> <p>Anti-slip</p> <p>Rutschhemmungsklassifizierung</p> <p>Classification glissement</p> <p>Классификация устойчивости к скольжению</p>	<p>A+B A+B+C</p> <p>DIN 51097</p> <p>Classificazione antiscivolosità</p> <p>Anti-slip</p> <p>Rutschhemmungsklassifizierung</p> <p>Classification glissement</p> <p>Классификация устойчивости к скольжению</p>	<p>V2</p> <p>Piastrelle con lieve variazione di tono e disegno</p> <p>Tiles with slight shade and aspect variation</p> <p>Fliesen mit leicht unterschiedlichen Tonalitäten und Muster</p> <p>Carreaux avec faible différence de nuance et structure</p> <p>Плитка с легким изменением тона и рисунка</p>	<p></p> <p>Ingelivo</p> <p>Frost-resistant</p> <p>Frostsicher</p> <p>Résistance au gel</p> <p>Морозостойкая</p>
<p>RET</p> <p> Rettificata</p> <p>Rectified</p> <p>Kalibriert</p> <p>Réctifié</p> <p>Ректифицированная</p>				
<p>Spessore mm</p> <p>Thickness mm</p> <p>Dike mm</p> <p>Epaisseur mm</p> <p>Толщина mm</p>				

Imballi, colori e misure sono soggetti a inevitabili variazioni.
Le informazioni contenute nel presente catalogo sono il più possibile esatte, ma non sono da ritenersi legalmente vincolanti.

Packings, colours and sizes are subject to inevitable variations.
The information contained in this catalogue is correct to the best of our knowledge, but it is not construed as legally binding.

Verpackungen, Farbe und Masse der Fliesen unterliegen unvermeidlichen Veränderungen.
Die im vorliegenden Katalog enthaltenen Angaben sind so genau wie möglich gehalten, sind aber auch rechtlich nicht verbindlich.

Changements de poids, nuances et dimensions sont typiques et inévitable. Les renseignements donnés dans ce catalogue sont le plus possible exacts, sans avoir effet obligatoire.

ceramica
SANT'AGOSTINO

Via Statale, 247 - 44047 S. Agostino (FE) ITALY

T. +39 0532 844111

F. Italia + 39 0532 846113

F. Export + 39 0532 844209

info@ceramicasantagostino.it

www.ceramicasantagostino.it